



1550 Series Electro-Hydraulic Servovalves

Sapphire Technology



2-stage mechanical feedback
Low mass, high band-width torque motor
High spool drive forces
Long life "Sapphire Technology" design
High resolution, low hysteresis
Rated flows 4 to 70 l/min at 70 bar
Standard & High Response
Internal pilot supply (4 port)
ISO 4401 size 5

Star Hydraulics Limited
8 Beta Close
Tewkesbury Business Centre
Tewkesbury
Gloucestershire
GL20 8SR
England (UK)

Technical Data

Nominal flow ratings at 70 bar Dp	4, 10, 20, 40, 60 & 70 l/min For other flow ratings consult factory
Hysteresis	< 3.0% without dither
Threshold	< 0.5% without dither
Null shift	
with 40 °C temp change	< 2%
with 70 bar supply pressure change	< 2%
with return pressure 0 to 35 bar	< 2%
Load pressure difference at 1% input	> 60% of supply pressure
Seal material options	FPM, NBR, EPDM
Temperature range (ambient)	-29 to 135 °C (subject to seal material)
Proof pressure	
at pressure port	150% operating pressure
at return port	100% operating pressure
Burst pressure	250% max supply pressure
External leakage	zero
Degree of protection EN 50529P	IP 65
Weight	1.1 kg
Vibration	30 g, 3 axes
Mounting position	Any, fixed or movable
Supply filtration	
non by-pass	Beta 10 = 200 (10 µm abs)
cleanliness control filter	Beta 3 = 200 (3 µm abs)
Fluid cleanliness level per ISO 4406: 1999	
minimum	16/ 14/ 12
recommended	14/ 12/ 10
Operating pressure (max)	
EPDM	210 bar
FPM, NBR	315 bar
Supply pressure	Constant
Fluid viscosity	10 to 100 cSt
Fluid type	Petroleum based mineral oil For operation with other media consult factory

Technical Data

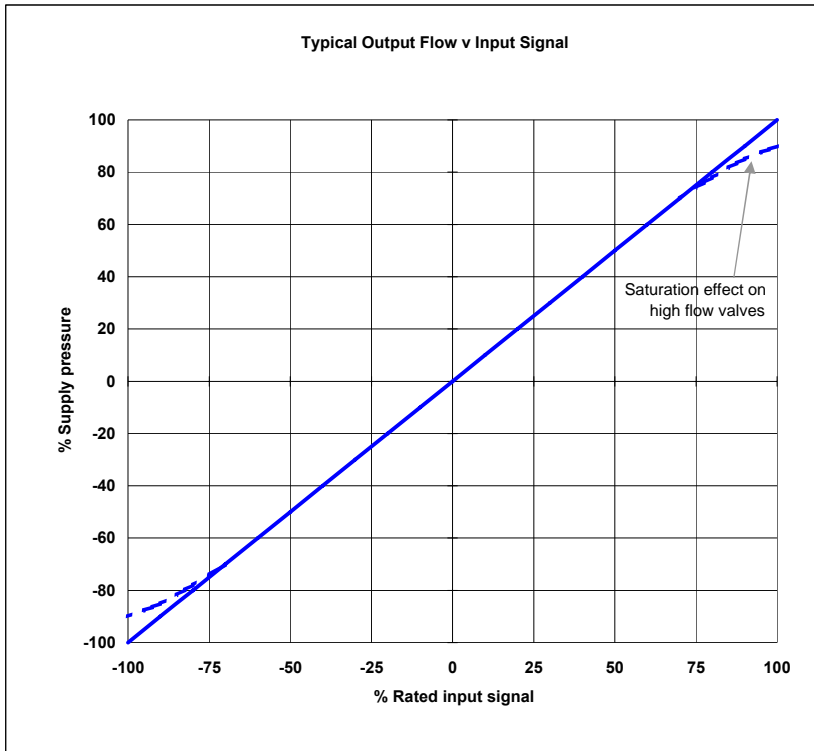

The flow tolerance for standard servovalves is $\pm 10\%$ of the rated flow at 100% rated input signal.

The rated flow is quoted at 70 bar Δp , 100% rated input signal.

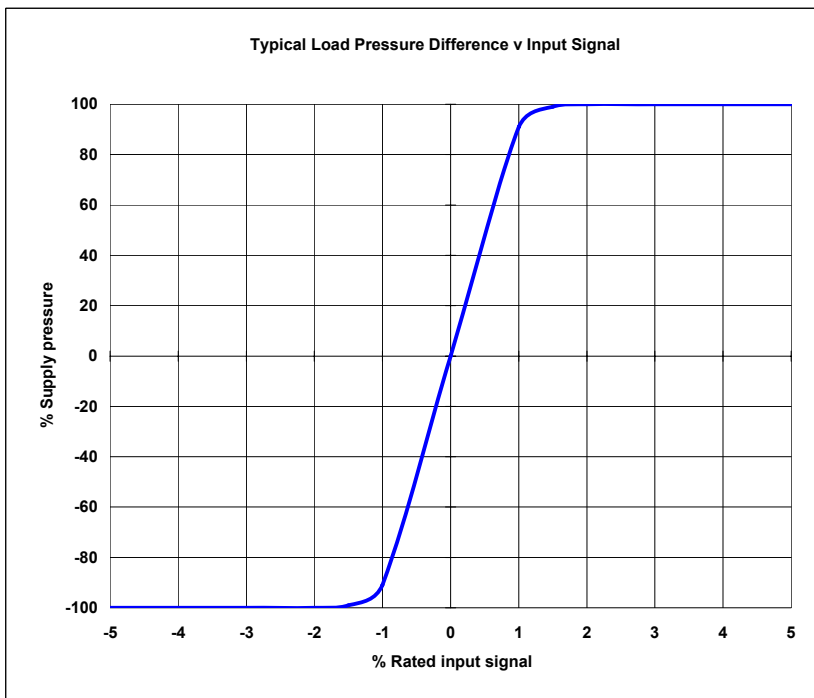

Pressure gain characteristic will vary with positive and negative lap conditions.

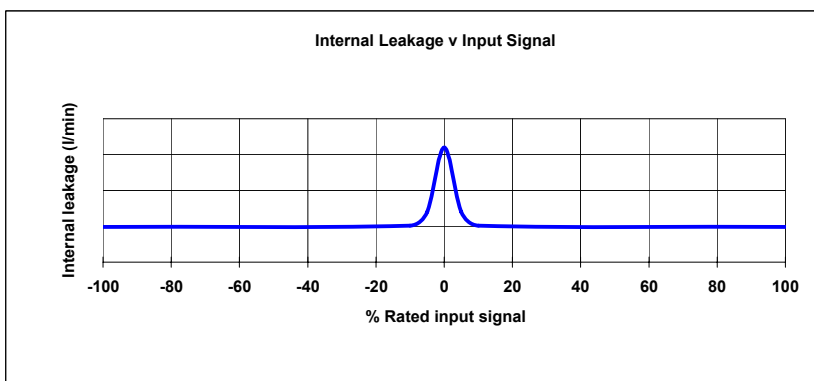

This comprises of both 1st stage flow (tare leakage) and the second stage null leakage.

Figures vary in accordance with rated flow, spool lap and performance characteristics.

Electrical Details

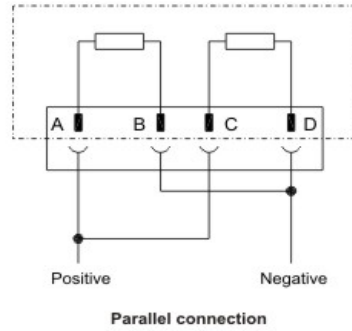
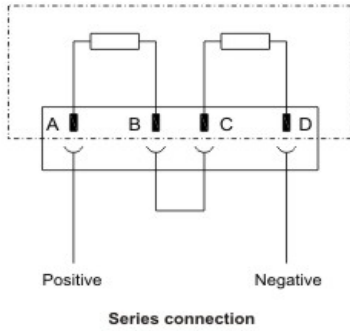

Output flow polarity

Flow in the direction of P » C2, C1 » R when coils connected as shown

Coil options

Rated current mA	Resistance / coil Ω	Series connection		Parallel connection	
		Input current mA	Effective resistance Ω	Input current mA	Effective resistance Ω
8	1000	4	2000	8	500
10	1000	5	2000	10	500
15	200	7.5	400	15	100
15	350	7.5	700	15	175
15	600	7.5	1200	15	300
20	1200	10	2400	20	600
30	300	15	600	30	150
30	800	15	1600	30	400
40	80	20	160	40	40
50	80	25	160	50	40
60	40	30	80	60	20
60	320	30	640	60	160
80	22	40	44	80	11
100	27	50	54	100	13.5
200	22	100	44	200	11

Electrical connector

Standard connector is MS3102E-14S-2P (MIL-5015)

Please contact factory for more options

Standard Frequency Response

25% In — 100% In —

Rated Flow (l/m) ... 4 ~ 20

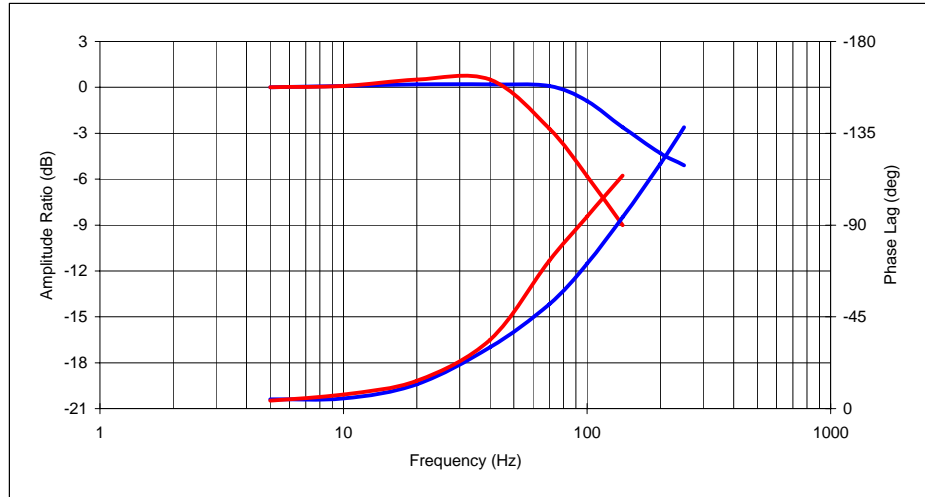

Rated Flow (l/m) ... 40

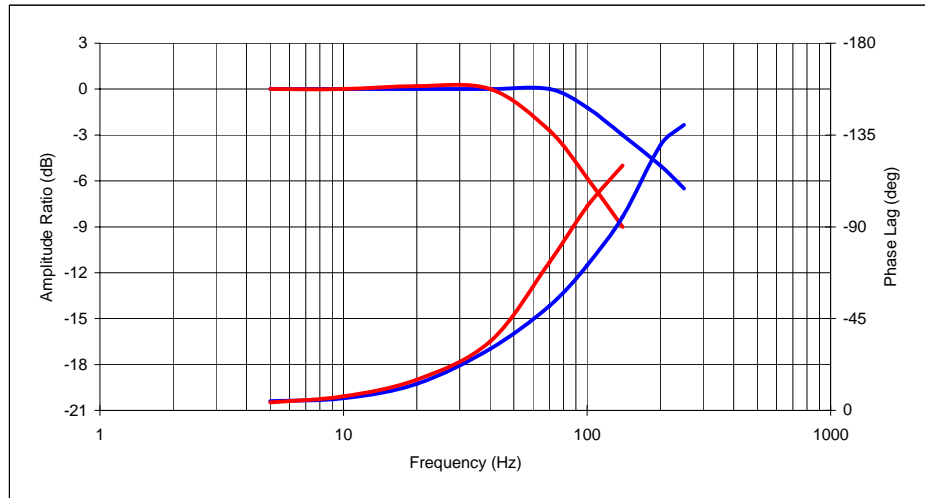

Rated Flow (l/m) ... 60

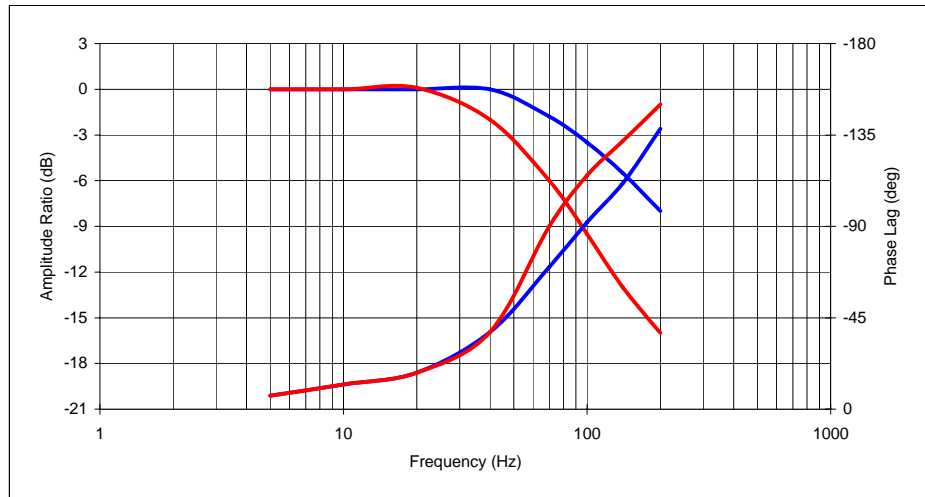

Typical performance curves optimised per 210 bar supply pressure, fluid viscosity 32 cSt at 40 °C

High Frequency Response

25% In — 100% In —

Rated Flow (l/m) ... 4 ~ 20

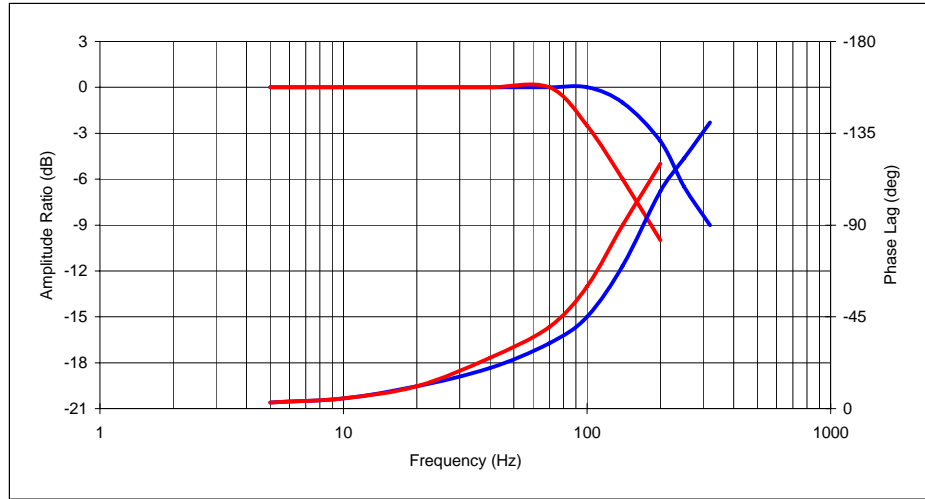

Rated Flow (l/m) ... 40

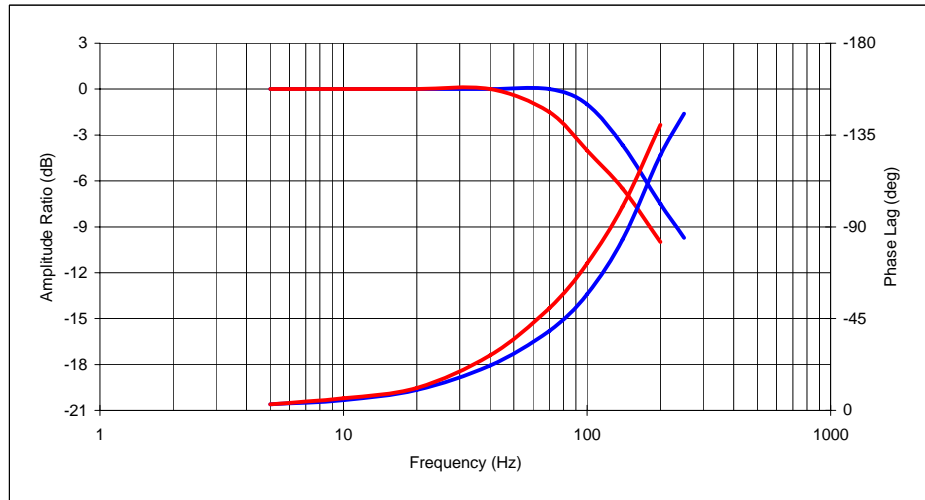

Typical performance curves optimised per 210 bar supply pressure, fluid viscosity 32 cSt at 40 °C

1. Suggested mounting bolts M6 x 50 long high tensile steel socket head cap screws.

2. 4-way electrical connector mates with MS3106-14S-2S or equivalent. Is available at $\pm 90^\circ$ and 180° to position shown (advise desired position at time of order).

3. Base O-Rings: 12.0 I/D x 2.0 section (5 pcs).

4. Null adjust requires 10 A/F ring spanner and 2.5 hexagon key. Flow out of C2 will increase with clockwise rotation of key.

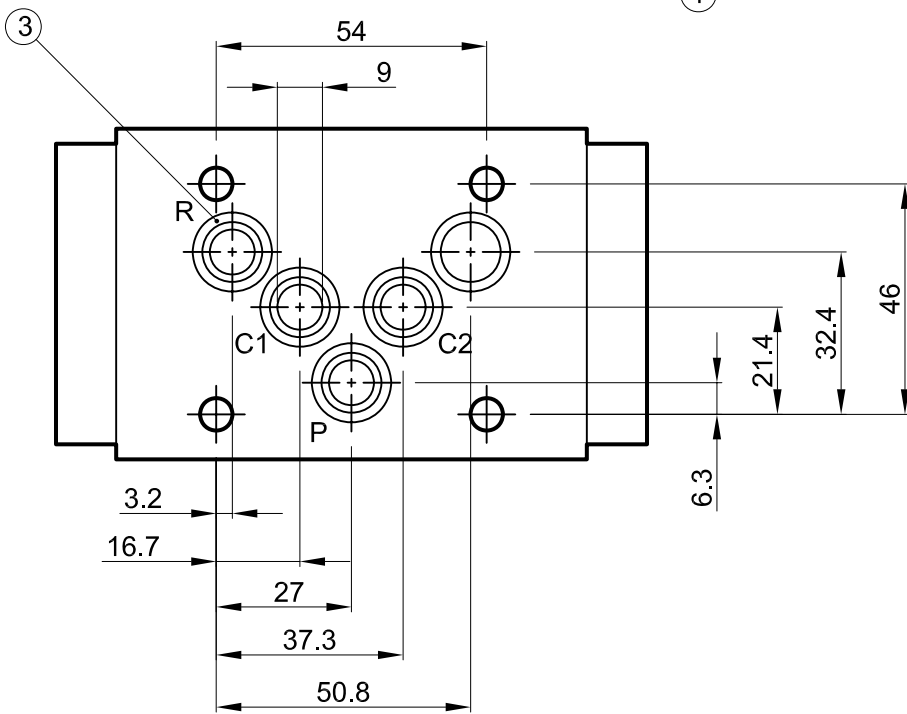
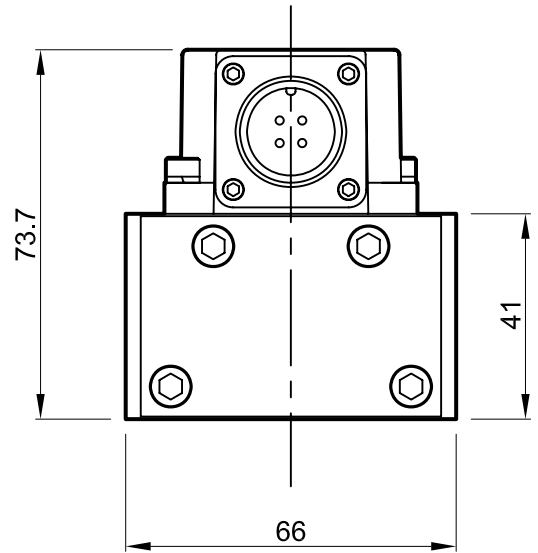
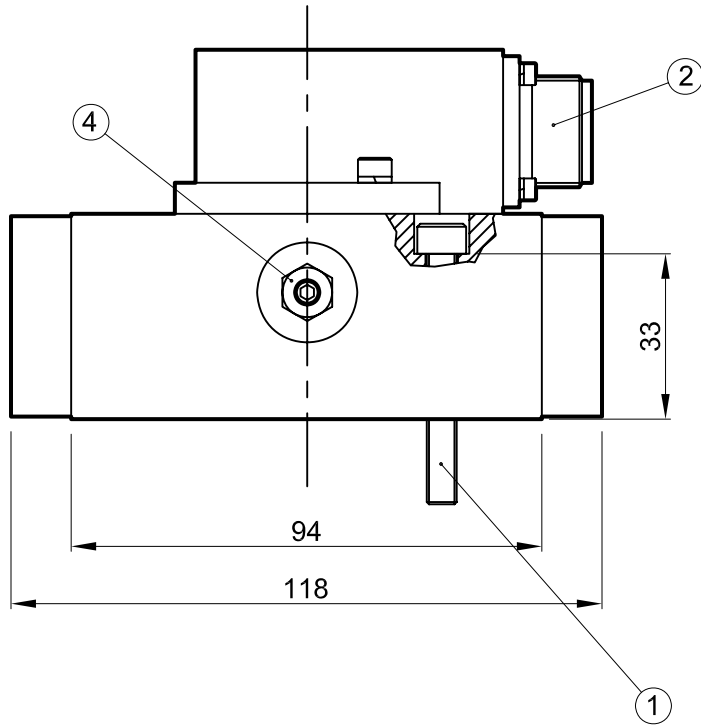

Installation Details Model 1550

Dimensions in millimeters
3rd angle projection

ID1550-2Q10-En

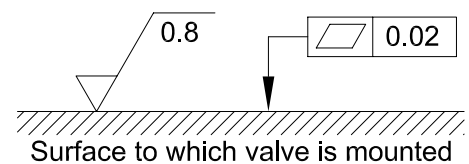

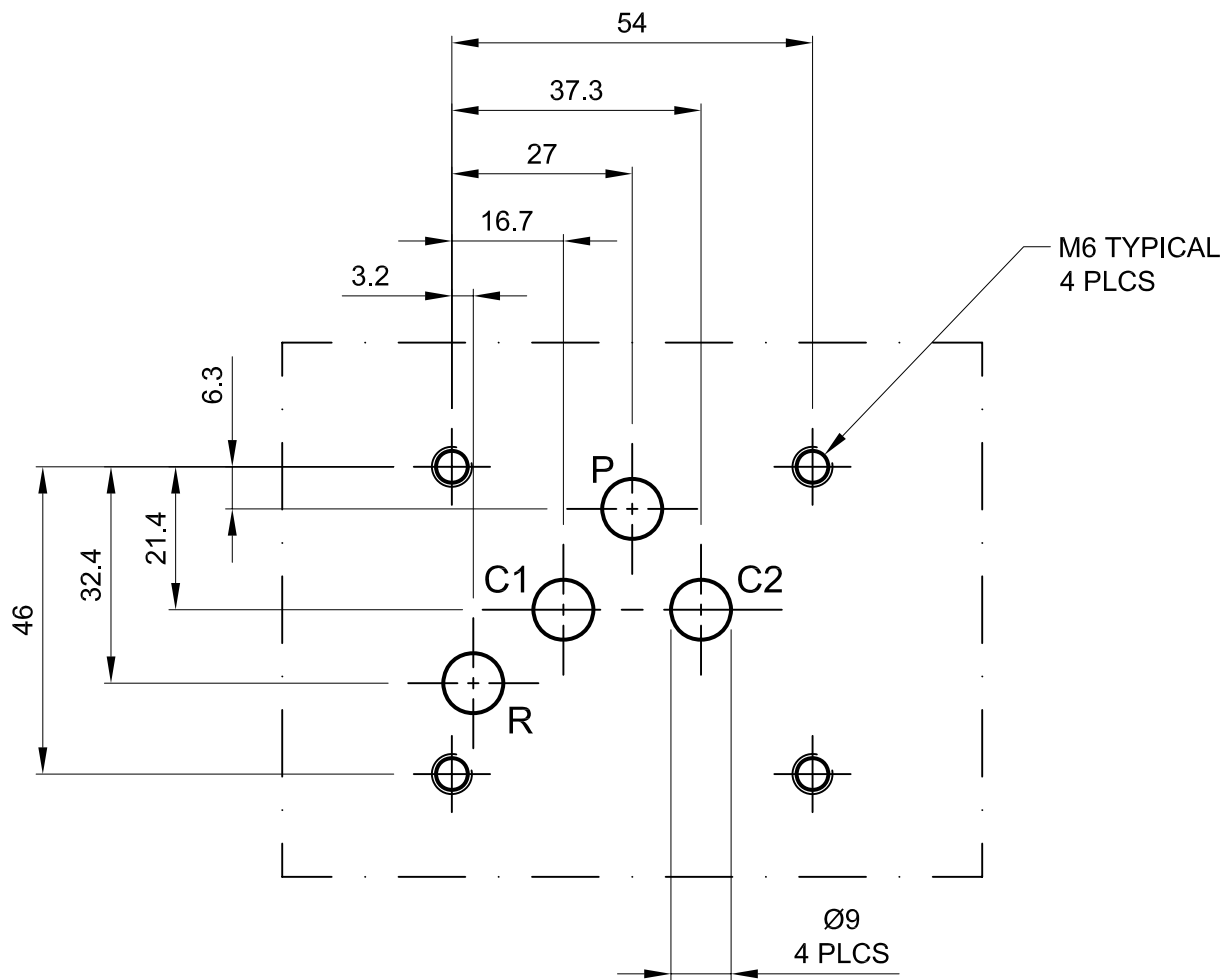

Manifold Dimensions Model 1550

Dimensions in millimeters
3rd angle projection

Filename

