

RS08

Rotary Shutter

Product Features

- Silent operation – undetectable
- Low surge current
- Best SWaP Performance
 - Mass: 3.6g
 - Embedded drive & control electronics in shutter body
- 90° in 130msec @ 25°C Typical
- Holding and braking without power consumption
- MIL-STD-810F Compliant for shock, vibration, and temperature – Safe & Reliable



ORDERING INFORMATION

Part Number:	RS080350AA-01
35° Stroke	
Part Number:	RS080450AA-01
45° Stroke	
Part Number:	RS080550AA-01
55° Stroke	
Part Number:	RS080700AA-01
70° Stroke	
Part Number:	RS080900AA-01
90° Stroke	
Part Number:	RS081200AA-01
120° Stroke	

RELATED PRODUCTS/ ACCESSORIES

Part Number:	RS08-EVAL-035
35° Kit	
Part Number:	RS08-EVAL-040
45° Kit	
Part Number:	RS08-EVAL-055
55° Kit	
Part Number:	RS08-EVAL-070
70° Kit	
Part Number:	RS08-EVAL-090
90° Kit	
Part Number:	RS08-EVAL-120
120° Kit	

Product Description

The RS08 is the first shutter of its kind, utilizing a silent, miniature piezo actuator in an 8mm x 20mm package including the drive electronics. The RS08 is designed to work from a 3.3v battery and supports travel ranges from 35° to 120°. Shutter blades can vary in size and material, up to a 25mm diameter paddle. Using Nanomotion's proprietary feedback system, the shutter is fully operational as a closed loop device, stopping on electrical limits to avoid any noise from a mechanical hardstop.

Optronic Systems

- Thermal imaging (NUC) shutters
- Laser Shutters
- Filters



TECHNICAL SPECIFICATIONS

Mechanical

- Weight: 3.6gr
- Dimensions: 8mm x 20mm Long

Performance

- Drive Mode: Closed Loop
- Stroke Angle: up to $120^\circ \pm 2^\circ$
- Operating Temperature: -40°C to 70°C
- Vibration (STd. Blade): 10g rms hold position without power
- Shock: 500g max. (non-operational)
- 90° in 130msec @ 25°C
- MTBF: 20,000 Hours Typ.
- Emissivity: >94% Between 8 to 14μ

ELECTRICAL

- Drive/Control Board Embedded
- Drive Voltage: 3.3V

Power Consumption (Page 5)

- Max: 400mW
- Idle (on): 8mW

Communication

- IIC

MECHANICAL DRAWINGS AND INTERFACE

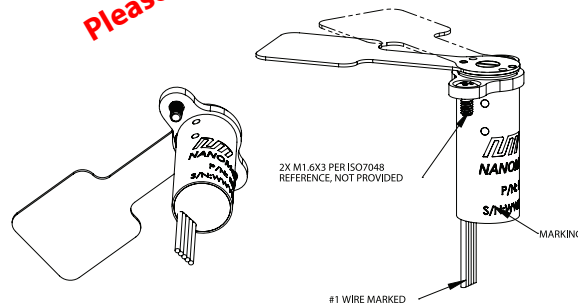
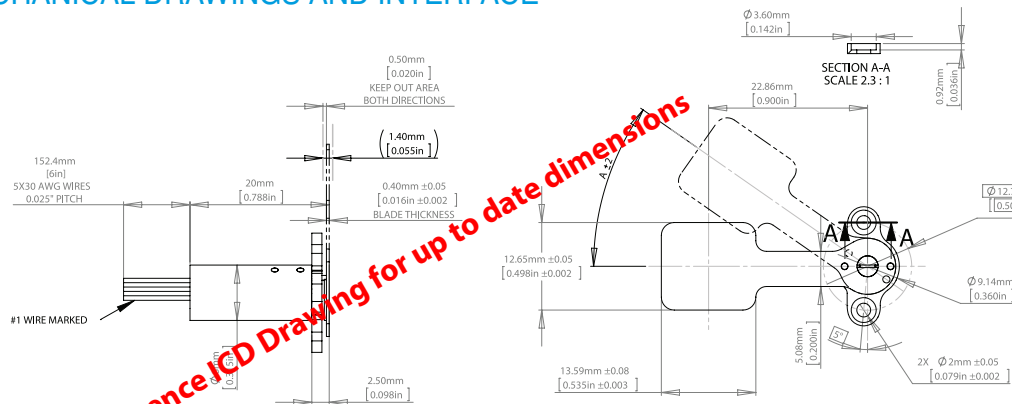

pin number	description
1	VCC 3.3V
2	GND
3	RESET/SHUTDOWN
4	SDA
5	SCL

stroke angle A (*)	RS08 P/N
35	RS080350AA-01
45	RS080450AA-01
55	RS080550AA-01
70	RS080700AA-01
90	RS080900AA-01
120	RS081200AA-01

ORDERING INFORMATION

RS08A Actuator consists of the shutter body with grid and mounting screw (no blade)

Part Number:	RS080350KA-01
35° Stroke	
Part Number:	RS080450KA-01
45° Stroke	
Part Number:	RS080550KA-01
55° Stroke	
Part Number:	RS080700KA-01
70° Stroke	
Part Number:	RS080900KA-01
90° Stroke	
Part Number:	RS081200KA-01
120° Stroke	

Product Features

- Blade-less actuator for shutter or filter change operation
- Silent operation – undetectable
- Low surge current
- Best SWaP Performance
 - Mass: 3.3g
 - Embedded drive & control electronics in shutter body
- 90° in 130msec @ 25°C Typical
- Holding and braking without power consumption
- MIL-STD-810F Compliant for shock, vibration, and temperature – Safe & Reliable

Product Description

The RS08A is the first actuator of its kind, utilizing a silent, miniature piezo actuator in an 8mm x 20mm package including the drive electronics. The RS08A is designed to work from a 3.3v battery and supports travel ranges from 35° to 120°.

The RS08A allows for user definable shutter blade or filter changer, based on appropriate motion analysis of mass and moment of inertia. Nanomotion's proprietary feedback system is integrated into the grid, for closed loop device operation, stopping on electrical limits to avoid any noise from a mechanical hardstop.

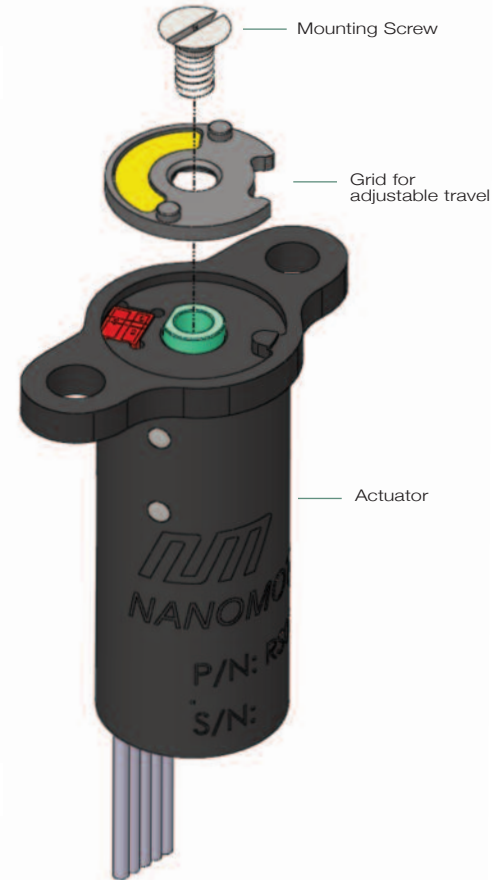

Optronic Systems

- Thermal imaging (NUC) shutters
- Laser Shutters
- Filters



TECHNICAL SPECIFICATIONS

Mechanical

- Weight: 3.3 gr
- Dimensions: Ø8mm x 20mm Long

Performance

- Drive Mode: Closed Loop
- Stroke Angle: up to 120° ±2°
- Operating Temperature: -40°C to 70°C
- Vibration: 10g rms hold position without power
- Shock: 500g max. (non-operational)
- 90° in 130msec @25°C
- MTBF: 20,000 Hours Typ.

ELECTRICAL

- Drive/Control Board Embedded
- Drive Voltage: 3.3V

Power Consumption (Page 5)

- Max: 400mW
- Idle (on): 8mW

Communication

- IIC

MECHANICAL DRAWINGS AND INTERFACE

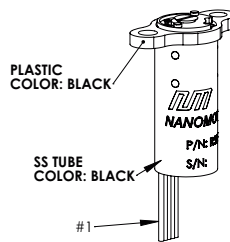
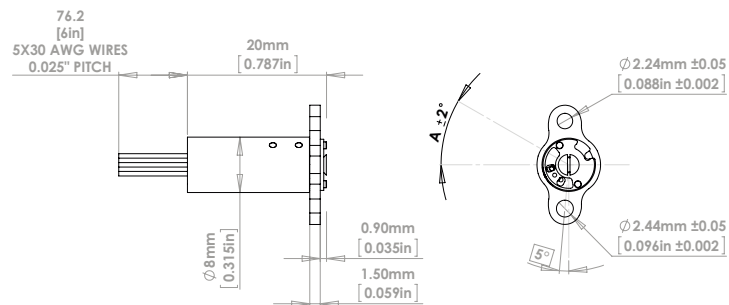

pin number	description
1	VCC 3.3V
2	GND
3	RESET/SHUTDOWN
4	SDA
5	SCL

Nanomotion Ltd. Worldwide Headquarters

Mordot HaCarmel Industrial Park
Yokneam 20692 Israel
t: +972 73 2498000
f: +972 73 2498099
e: nano@nanomotion.com

Nanomotion Inc. U.S. Headquarters

1 Comac Loop, Suite 14B2
Ronkonkoma, New York 11779
t: (800) 821-6266
t: (631) 585-3000
f: (631) 585-1947
e: nanoUS@nanomotion.com

RS08

Rotary Shutter Current Consumption

Product Description

The RS08 Rotary Shutter is designed to operate with the lowest power consumption, over all other shutter technologies. The normal force of the piezo actuator, inside the shutter body, provides built-in holding and braking without power consumption. This eliminates the need for any 'magnetic latching' to hold position (which requires a peak current to overcome, resulting in reduced battery life).

The chart below reflects the minimum, maximum and average power consumption relative to data points taken at different PWM values. At 40% PWM, the expected shutter actuation time is approximately 70msec. At 60% PWM, the expected actuation time is 55msec.

